

SERVICE MANUAL FOR
PHILIPS RECEIVER TYPE 141U

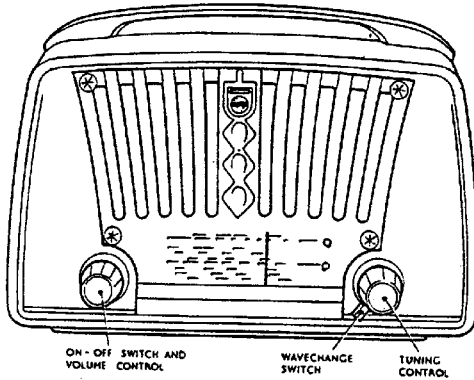

Front view of Receiver

VALVE COMBINATION

- V1 UCH42 Frequency changer.
- V2 UF41 I.F. Amplifier.
- V3 UBC41 Detector, A.F. Amplifier, A.G.C.
- V4 UL41 Power amplifier.
- V5 UY41 Mains rectifier.

MAINS CONSUMPTION

With 245 V. 50 c/s applied to the 220/250 V. tapping, the consumption (measured with a moving iron instrument) is approximately 230 mA.

PILOT LAMP

Type 8097D-00 (19 V., 0.09 A.).

VOLTAGE RANGE

200/250 V. D.C./A.C., 50/100 c/s.

WAVEBAND RANGES

- M.W. 1622-517 Kc/s. (185-580 m.).
- L.W. 261-150 Kc/s. (1150-2000 m.).

DIMENSIONS OF CABINET (overall)

Height 8½". Width 12½". Depth 6½".

TRIMMING FREQUENCIES

- I.F. 470 Kc/s.
- M.W. 550 Kc/s., 1630 Kc/s.
- L.W. 152 Kc/s.

REMOVING THE BACK AND BASEPLATES

The back and baseplates are combined, and are held by two 4mm. bolts through the baseplate, and four captured screws through the backplate.

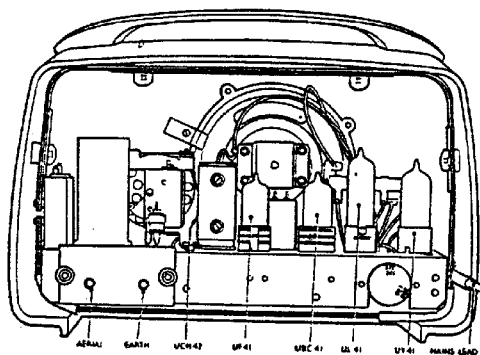

Back view of Receiver

REMOVING THE KNOBS

The two plastic knobs are held by grub screws threaded into the control spindles. The plastic wave change switch control slides off the spindle once the tuning knob has been removed. It is located in a keyway and, when replacing, care should be taken to ensure that it is in its correct position.

REPLACING THE PILOT LAMP

Remove backplate/baseplate assembly.

The pilot lamp holder is held to the chassis by one 3mm. bolt.

REMOVING THE SCALE

The scale is held to the cabinet by four ornamental bolts.

REMOVING THE CHASSIS

Remove the backplate/baseplate assembly.

Remove the knobs.

Remove the scale.

Turn the gang to maximum capacitance.

Remove the two chassis fixing bolts which bolt into the rear of the cabinet front and, guiding the pointer through the slot in the cabinet, withdraw the chassis.

Replace in the reverse order.

REPLACING THE CORD DRIVE

(See Fig. 1)

Make up the cord to the length indicated.

Turn the gang to maximum capacitance.

Fit the spring to its anchor point on the drum.

Hook one end of the cord to the spring, and pass the cord under the stud on the drum, through the hole in, and clockwise round the drum. Loop the cord round the drive spindle in the direction indicated on the figure. (This operation can be easily carried out if the receiver chassis is allowed to overhang the work bench, when advantage can be taken of the "V" cut out in the chassis flange to loop the cord over the spindle.) Pass the cord under the stud, round the end pulley, back and under the other stud and round the spindle as indicated. It is important to get the two sets of turns round the spindle in the correct directions, and in their correct relative positions as indicated in the diagram. Pass the cord clockwise round the drum as far as the top. At this point, pull the cord taut, and at the same time stretch (with pliers) the spring. Hold the cord to the drum with one finger, pass the cord on clockwise round the drum, through the hole in the drum, over the stud, and hook the end on to the spring. Gently release the cord to allow the spring to take up its normal tension.

The fixing of the pointer to the cord is evident from the diagram. There are two turns of cord round the pointer base. To avoid bending the pointer base, push the first turn of cord (which is easily fitted) up towards the pointer end of the base. Then the second turn can be easily fitted.

With the gang at minimum, the pointer should be adjusted so that its centre lines up with the "d" in "Third."

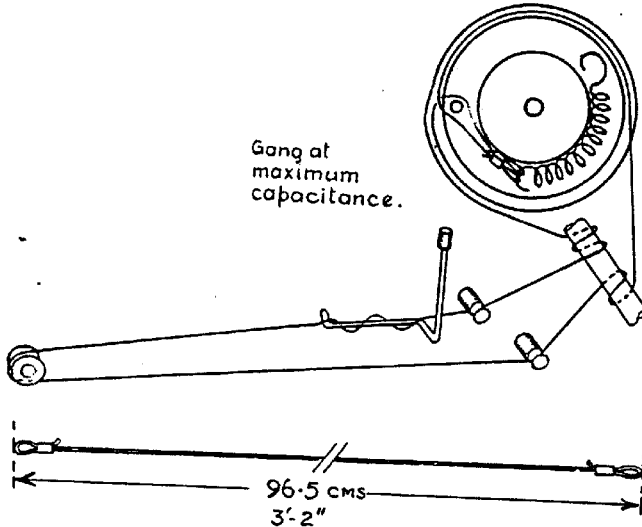

FIG. 1

TRIMMING INSTRUCTIONS

(a) I.F. Circuits

Set gang capacitor to its mid position.

Switch to M.W.

Set volume control to maximum.

Unscrew the cores of the I.F. transformers a few turns.

Apply a signal of 470 Kc/s to g1V1 via a coupling capacitor of 47 KpF. Trim cores for maximum output in the following order, S18, S17, S16 (top core), S15 (bottom core).

(b) Pointer Setting

With the gang at minimum, the centre line of the pointer should line up with the "d" in "Third."

(c) Aerial and Oscillator Circuits.

The oscillator frequency = tuning frequency + I.F.

Set volume control to maximum.

Apply the signal between the aerial socket and chassis with the loop aerial connected and in position.

(i) Medium Waves

Adjust the gang so that the pointer lines up with the right-hand end of the R. Eireann (i.e. 550 Kc/s. position) station block. Apply a modulated signal of 550 Kc/s. and trim S12 and S4 for maximum output.

With gang at minimum capacitance, apply 1630 Kc/s. and trim C17 and C5 for maximum output.

Repeat the above.

(ii) Long Waves

Tune the receiver to a signal of 152 Kc/s. and trim S6 for maximum output.

SPARE PARTS LIST—TYPE 141U

IMPORTANT. When ordering spare parts, the type number of the receiver and the code number of the part, as given in this manual, **MUST** be quoted to enable the order to be correctly executed. When claiming free replacement under guarantee, the defective part should be returned and the type and serial number of the receiver, also the date of sale, should be quoted.

CABINET ASSEMBLY

Cabinet (moulded)	MK.975.92/MJ
Philips emblem	A3.357.11
Pins for above	A3.314.02

CONTROL KNOBS

Control knobs—Volume and Tuning	MK.854.52
Control levers—Waveband and Tone Switch	MK.922.16/MJ
Moulded ring behind Volume Control knob	MK.448.49/MJ
Felt rings for knobs	MK.447.88
Felt rings for levers	MK.447.91
Grub screws for knobs	A3.324.16

BACKPLATE (MOULDED)

... ..	MK.975.94/MJ
Screws for above	MK.946.82
Washers for above	MK.448.52
Valve position label	PG.002.17
Limited licence label	PG.005.23

BASEPLATE ASSEMBLY

... ..	MK.874.88
--------	-----------

SCALE ASSEMBLY

Station scale (plastic)	MK.704.31
Ornamental screws for above	A3.713.10

POINTER only

... ..	A3.693.96
Felt ring for above	A3.561.66

LOUDSPEAKER complete

... ..	MK.860.93
Felt strips under above	MK.678.42
Speaker holding clamps	MK.046.91

CHASSIS ASSEMBLY**POINTER DRIVE ASSEMBLY**

Pulley 200m. end	MK.930.99
Spacer for above	A3.562.82
Brass guides for drive cord 550m. end	A3.600.42
Drive cord only	G6.608.28
Cord loop grips	MK.908.99

TUNING UNIT

Gang capacitor with large drum	4V.480.47
Distance pieces for above	07.005.26
Circlip for small inner drum	A3.563.36
Cord tension spring	A3.646.26
Tuning spindle and bracket assembly complete	MK.827.37

WAVEBAND SWITCH SECTION

... ..	MK.889.60
--------	-----------

WAVEBAND SPINDLE ASSEMBLY...

... ..	A3.662.61
Metal washer for above	49.922.12
Felt washer for above	A3.562.81
Retaining clip	A3.652.72
Steel ball for stop plate ($\frac{3}{32}$ "")	89.205.05
Phosphor bronze leaf springs (5)	A3.648.79
Small holding bracket for above	A3.452.52
Moulded operating gear	MK.912.02

PILOT LAMPHOLDER

... ..	A3.359.07
Screen for above	MK.032.98
Spire clips for screen	A3.321.46

VOLUME CONTROL AND SWITCH ASSEMBLY

... ..	49.500.34
Volume control only	MK.810.07
Mains switch only	08.529.38
Insulator between switch and control	28.315.23
Control spindle	MK.002.93

FRAME AERIAL

... ..	MK.230.23
--------	-----------

SPARE PARTS LIST—TYPE 141U—(Contd.)

COMPONENT RACK FOR MOUNT-
ING RESISTORS, etc.

Support clip for above ...	28.682.08
Solder strip for above—single-way ...	A1.477.09
Solder strip for above—two-way ...	28.032.86
Solder strip for above—two-way ...	28.032.84

MISCELLANEOUS

{ Voltage adjustment disc only ...	MK.854.53
{ Voltage adjustment pin plate only ...	A3.228.39
Spacer for above ...	07.014.31
Aerial/Earth socket plate assembly ...	A3.388.29
Valveholders ...	49.232.02
Spring clips for coils ...	MK.730.23
Fixing bracket for S15/16 ...	28.084.83
Core retainer for S4 ...	A3.307.73
Compression spring for R2/3/4 ...	A3.644.53
Washer for above ...	MK.476.43
Mains lead only ...	K3.975.00
Clamp bracket for above ...	25.038.33
Rubber bushes for chassis ...	A3.563.01
Chassis fixing screws (4 × 8mm.) ...	07.804.08
*Some models use	
Voltage adjustment disc only ...	MK.854.64
Voltage adjustment pin plate only ...	MK.875.51

GENERAL (Screws, nuts, etc.)

CHEESEHEAD SCREWS

2 × 10mm. 07.800.10	3 × 15mm. ...	07.803.15
3 × 5mm. 07.803.05	3 × 25mm. ...	07.803.25
3 × 6mm. 07.803.06	4 × 6mm. (brass)	07.704.06
3 × 6mm. (brass) 07.703.06	4 × 8mm. ...	07.804.08
3 × 8mm. 07.803.08		

WASHERS

3mm. 07.035.30	4mm. ...	07.014.40
----------------	----------	-----------

NUTS

3mm.	07.104.30
----------	-----	-----------

VALVES AND PILOT LAMP

V1 Valve	UCH42
V2 Valve	UF41
V3 Valve	UBC41
V4 Valve	UL41
V5 Valve	UY41
L1 Pilot lamp (19 V. .097 amp.)	...	00.080.97D-00

TRANSFORMERS AND COILS

S3-7 Aerial coil M.W. and L.W. ...	MK.565.23
S11/12 Oscillator coil M.W. and L.W. ...	MK.565.13
S15/16 1st I.F. coil ...	MK.564.56
S17/18 2nd I.F. coil ...	A3.124.47
S19/20 Speaker transformer ...	A3.151.99
S21 Loudspeaker ...	MK.800.93

CORE for S4 ...	A3.368.19
Core for S6 ...	A3.368.20
Cores for S15/16 ...	23.644.67
Cores for S17/18 ...	A3.367.77

WAX for air capacity trimmers ...	GBX.008.13/01
Wax for 1st I.F. coil ...	GBX.009.47

SPARE PARTS LIST—TYPE 141U—(Contd.)

CAPACITORS

				Working Voltage	Permitted Tolerance	
C1/2	Electrolytic	...	50 + 50 uF	250V		MK.182.25/50+50
C3	Paper	...	1,000 pF	800V	20%	48.757.20/1K
C5	Trimmer	...	3-30 pF			28.212.36
C6	Ceramic	...	111 pF		1%	48.406.01/111E
C8/9	Gang	...	11-500 pF			4 V.430.47
C10	Ceramic	...	100 pF		20%	48.406.10/100E
C12	Paper	...	47,000 pF	125V	20%	48.750.10/47K
C13	Ceramic	...	470 pF		20%	48.406.10/470E
C14	Ceramic	...	47 pF		20%	48.406.10/47E
C15	Ceramic	...	419 pF		1%	48.406.01/419E
C17	Trimmer	...	3-30 pF			28.212.36
C18	Ceramic	...	460 pF		1%	48.406.01/460E
C20	Paper	...	0.1 uF	400V	20%	48.751.10/100K
C22		...	115 pF			} In 1st I.F. coil
C23		...	115 pF			
C24		...	110 pF			} In 2nd I.F. coil
C25		...	110 pF			
C26	Ceramic	...	100 pF		10%	48.406.10/100E
C27	Ceramic	...	390 pF		10%	48.406.10/390E
C29	Paper	...	10,000 pF	400V	20%	48.751.10/10K
C30	Paper	...	22,000 pF	800V	20%	47.757.20/22K
C31	Paper	...	2,200 pF	400V	20%	48.751.10/2K2
C32	Paper	...	33,000 pF	600V	20%	48.752.10/33K
C34	Paper	...	4,700 pF	800V	20%	48.757.20/4K7
C37	Paper	...	15,000 pF	125V	20%	48.750.10/15K

RESISTORS

N.B.—Wattage is based upon an ambient temperature of 70°C.

				Wattage	Permitted Tolerance	
R1		...	1,000 Ohm	1 watt	10%	} 48.427.10/1K
R2		...	240 Ohm	5 watt	5%	
R3	} Wirewound	...	250 Ohm	2.5 watt	10%	
R4		...	538 Ohm	5.4 watt	10%	
R5	N.T.C.	{ Cold 2,000-3,500 Ohm Hot 220 Ohm approx.				} 49.379.62
R6		...	0.68M Ohm	1/2 watt	20%	
R7		...	22,000 Ohm	1 watt	10%	} 48.426.10/680K
R8		...	22,000 Ohm	1 watt	10%	
R9		...	18,000 Ohm	1/2 watt	10%	} 48.427.10/22K/M
R10		...	18,000 Ohm	1 watt	10%	
R12		...	1.5M Ohm	1 watt	10%	} 48.426.10/22K
R13		...	4.7M Ohm	1/2 watt	20%	
R14	} Potentiometer	{ 0.05M Ohm 0.45M Ohm		1/2 watt	20%	} 48.426.10/1M5
R15			...	0.22M Ohm	1/2 watt	
R16		...	0.68M Ohm	1 watt	10%	} 48.426.10/4M7
R17		...	150 Ohm	1 watt	10%	
R18		...	0.1M Ohm	1 watt	10%	} 49.500.34
R19	N.T.C.	{ Cold 8,000-15,000 Ohm Hot 200-280 Ohm approx.		1/2 watt	20%	
R20		...	10,000 Ohm	1/2 watt	10%	} 48.426.10/220K
R21		...	1,000 Ohm	1/2 watt	10%	
R24		...	1.0M Ohm	1 watt	10%	} 48.426.10/680K
R25		...	15,000 Ohm	1 watt	10%	
						} 48.427.10/150E
						} 48.426.10/100K
						} 49.379.67
						} 48.426.10/10K
						} 48.426.10/1K
						} 48.426.10/1M
						} 48.426.10/15K

SPARE PARTS LIST—TYPE 141U—(Contd.)

CAPACITORS

				Working Voltage	Permitted Tolerance	
C1/2	Electrolytic	...	50 + 50 uF	250V		MK.182.25/50 + 50
C3	Paper	...	1,000 pF	800V	20%	48.757.20/1K
C5	Trimmer	...	3-30 pF			28.212.36
C6	Ceramic	...	111 pF		1%	48.406.01/111E
C8/9	Gang	...	11-500 pF			4 V.430.47
C10	Ceramic	...	100 pF		20%	48.406.10/100E
C12	Paper	...	47,000 pF	125V	20%	48.750.10/47K
C13	Ceramic	...	470 pF		20%	48.406.10/470E
C14	Ceramic	...	47 pF		20%	48.406.01/47E
C15	Ceramic	...	419 pF		1%	48.406.01/419E
C17	Trimmer	...	3-30 pF			28.212.36
C18	Ceramic	...	460 pF		1%	48.406.01/460E
C20	Paper	...	0.1 uF	400V	20%	48.751.10/100K
C22		...	115 pF			} In 1st I.F. coil
C23		...	115 pF			
C24		...	110 pF			} In 2nd I.F. coil
C25		...	110 pF			
C26	Ceramic	...	100 pF		10%	48.406.10/100E
C27	Ceramic	...	390 pF		10%	48.406.10/390E
C29	Paper	...	10,000 pF	400V	20%	48.751.10/10K
C30	Paper	...	22,000 pF	800V	20%	47.757.20/22K
C31	Paper	...	2,200 pF	400V	20%	48.751.10/2K2
C32	Paper	...	33,000 pF	600V	20%	48.752.10/33K
C34	Paper	...	4,700 pF	800V	20%	48.757.20/4K7
C37	Paper	...	15,000 pF	125V	20%	48.750.10/15K

RESISTORS

N.B.—Wattage is based upon an ambient temperature of 70°C.

				Wattage	Permitted Tolerance	
R1		...	1,000 Ohm	1 watt	10%	} 48.427.10/1K
R2		...	240 Ohm	5 watt	5%	
R3	} Wirewound	...	250 Ohm	2.5 watt	10%	
R4		...	538 Ohm	5.4 watt	10%	
R5	N.T.C.	{ Cold 2,000-3,500 Ohm Hot 220 Ohm approx.				} 49.379.62
R6		...	0.68M Ohm	1/2 watt	20%	
R7		...	22,000 Ohm	1 watt	10%	} 48.426.10/680K
R8		...	22,000 Ohm	1/2 watt	10%	
R9		...	18,000 Ohm	1 watt	10%	} 48.427.10/22K/M
R10		...	1.5M Ohm	1 watt	10%	
R12		...	4.7M Ohm	1/2 watt	20%	} 48.426.10/18K
R13		...	0.05M Ohm	1/2 watt	20%	
R14	} Potentiometer	...	0.45M Ohm		Log law	} 48.426.10/1M5
R15		...	0.22M Ohm			
R16		...	0.68M Ohm	1 watt	10%	} 49.500.34
R17		...	150 Ohm	1 watt	10%	
R18		...	0.1M Ohm	1 watt	10%	} 48.427.10/150E
R19	N.T.C.	{ Cold 8,000-15,000 Ohm Hot 200-280 Ohm approx.		1/2 watt	20%	
R20		...	10,000 Ohm			} 48.426.10/100K
R21		...	1,000 Ohm	1/2 watt	10%	
R24		...	1.0M Ohm	1/2 watt	20%	} 48.426.10/1K
R25		...	15,000 Ohm	1/2 watt	10%	

Valve No	Voltages (20,000 nV. Meter)			Currents (mA.)			Vc1 - 210V Vc2 - 182V
	Va	Va. osc	Vg2	Vk	Ia	Ia. osc.	
V1	182	92	78	-	3.7	3.5	-
V2	182	-	78	-	5.5	-	-
V3	70	-	-	-	0.5	-	-
V4	196	-	182	8.2	48	-	-
V5	-	-	-	-	-	-	72

A.V.C. Voltages.
 With a signal of 150 mV at 1 Mc/s applied to the aerial socket, the voltages are approximately as follows. (measured on a valve voltmeter.)
 Junction S18/C26 13 v | 51 V2 12.4 v
 " C12/R10 12.5 v | 51 V1 12.2 v

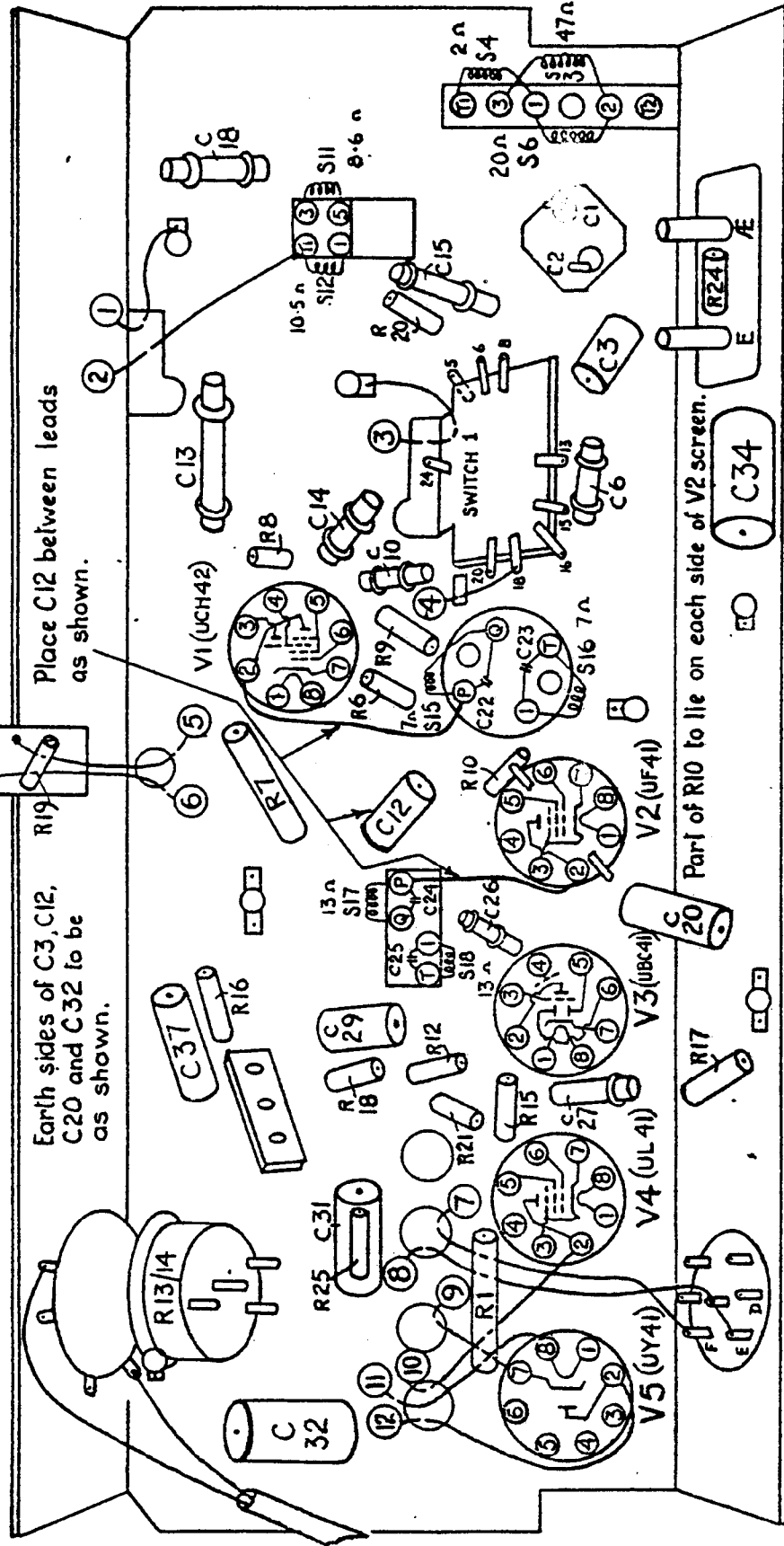

S	18.	15.	16.	12.	11.	6.	3.	4.				
C	32.	31.	27.	37.29.	25.26.20.24	12.	10.	14.6.34.13.	3.	15.2.	1.	18.
R	1.	13.4.25.	21.15.18.17.12.16.	19.7.10.	6.	9.	8.	20.24.				

UNDER VIEW OF CHASSIS

ERRATA.
 Contacts 13 and 15 on the switch, are on the side of the wafer opposite to that shown above.

S:-	3.	11, 12.	15, 16.	17, 18.	19, 20, 21.
C:-	3, 34, 6.	6, 10, 5.	14, 13, 16, 15, 20, 9, 17, 22.	23, 24, 37, 25, 26, 31, 32.	2, 29.
R:-	24.	6, 7, 8.	9, 20.	10, 25, 13.	12, 4, 10, 15, 2, 16, 21, 1, 17.

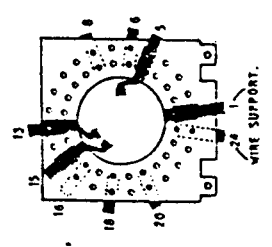
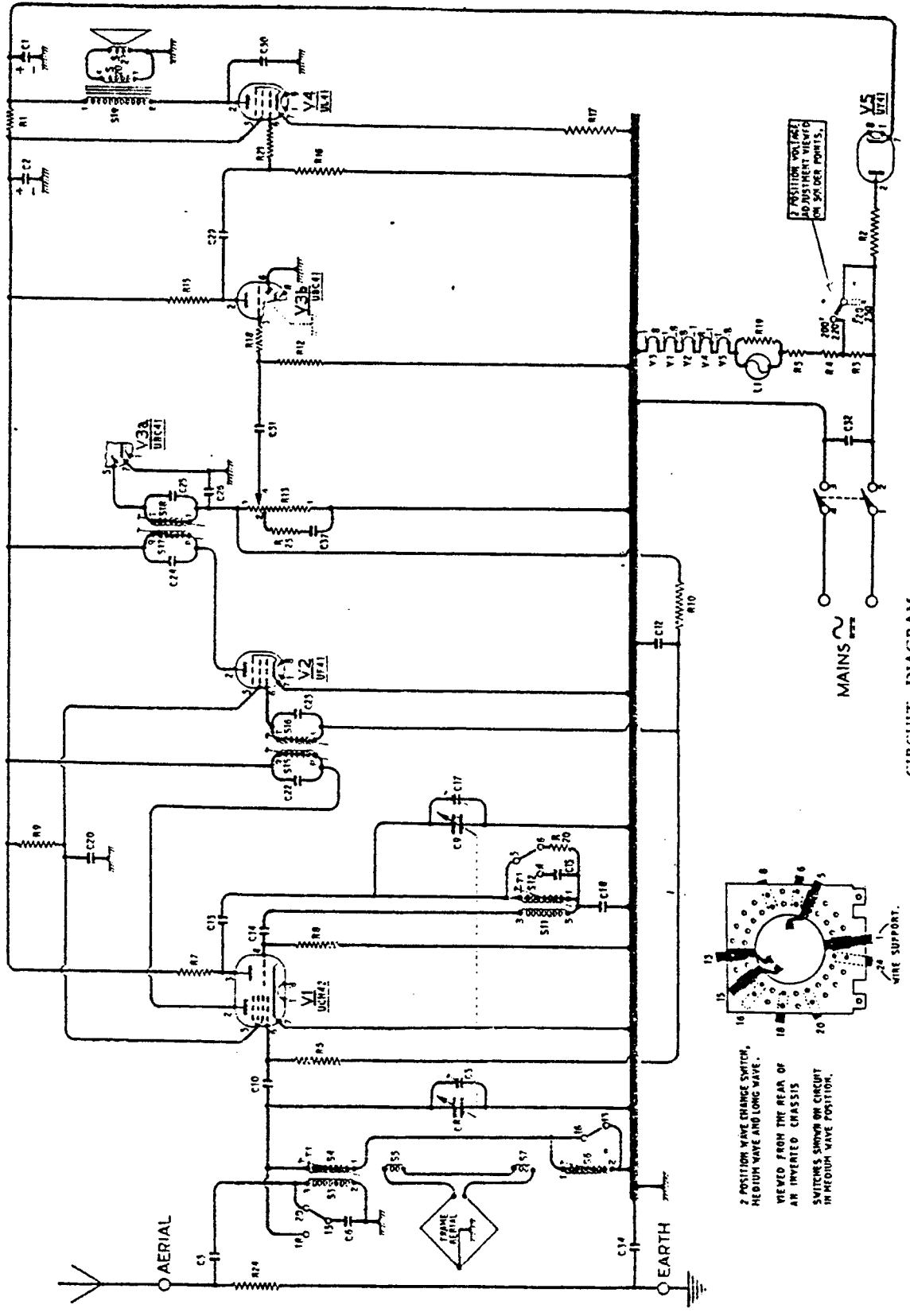

2 POSITION WAVE CHANGE SWITCH, MEDIUM WAVE AND LONG WAVE. VIEWED FROM THE REAR OF AN INVERTED CHASSIS SWITCHES SHOWN ON CIRCUIT IN MEDIUM WAVE POSITION.

CIRCUIT DIAGRAM